

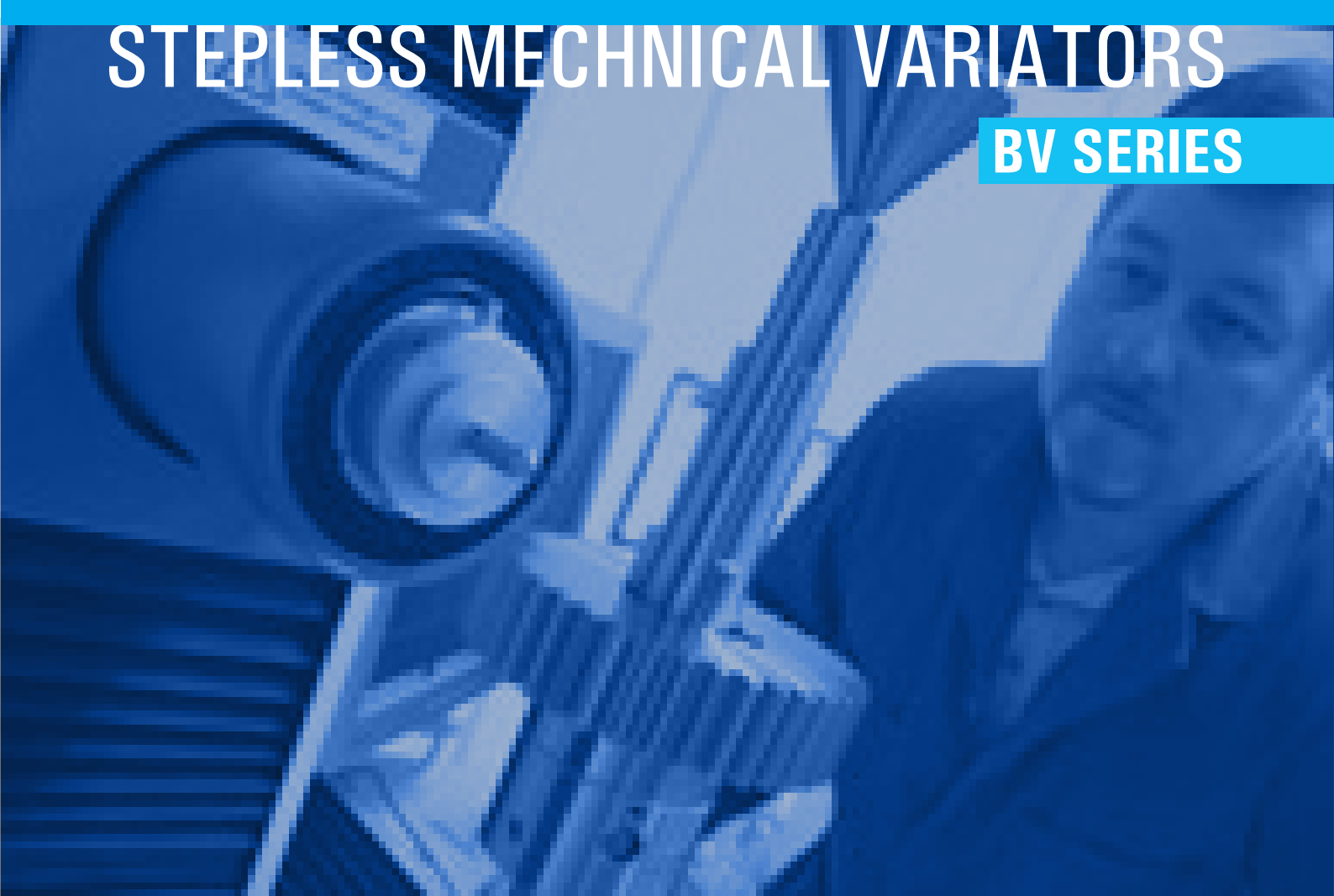

**BONVARIO**  
EURODRIVES

# STEPLESS MECHANICAL VARIATORS

**BV SERIES**



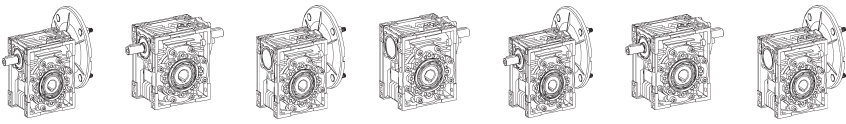

BONVARIO Group born in 1981 is presently one of the leading industrial automation products suppliers in Italy. Our Automation solutions are widely accepted worldwide majorly in countries like Germany, UK, Russia, Belgium, Denmark, Spain, Romania, Turkey, USA, Canada, Australia, South Africa, India and Japan. Our products are sold globally through various Branch offices, Automation solution centres and channel partners who are dedicated to serve our customers not only with reliable products but also with reliable pre n post sales assistance.

The name Bonvario came from joining two words - Bon & Vario, Bon is a French word which means good and Vario is an Italian word which means varied or various. These two words were coupled together to project good various speed gearboxes or geared motors which has always been the true identity of our group.

BONVARIO is innovation, quality, and service all in one. We prove this to our customers every day and have done so for the last 3 decades. We do not just move countless conveyer belts, bottling plants, assembly lines, processes in the chemical industry, your luggage at the airport, or even you on escalators. We also are moving ourselves. In our company everyday new researches are initiated and improvements are done based on results to shape a better automated future. Collectively more than 1100 employees & our various automation solution centres, around the world are moving to develop solutions that help you optimize your process. This is how Bonvario has evolved to become a major supplier of gearboxes & motors in the world market today with a turnover of euro 61 million.

## PRODUCT RANGE

### ALUMINIUM CASING GEARBOXES



BL SERIES



BVF SERIES

### HELICAL GEARBOXES

BON SERIES

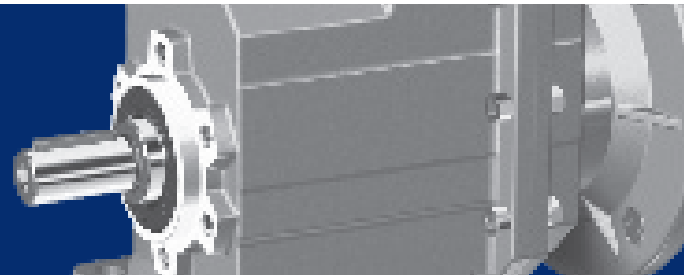
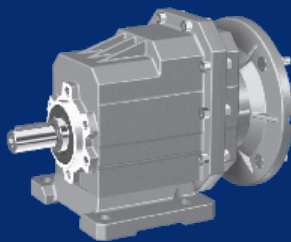

### HELICAL GEARBOXES



BH SERIES



### ELECTRIC MOTORS

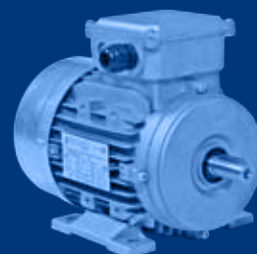

BM SERIES

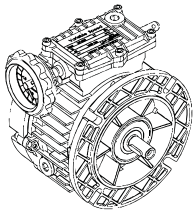

## BV SERIES STEPLESS MECHANICAL VARIATOR

### Summary

BV series planet cone-disk stepless mechanical variator is a new generation of products developed by ourselves on the basis of advanced technology. BV series stepless mechanical variator are widely used for conveying, ceramics, packing, chemical, textile, foodstuffs, medicine, printing, rubber, Machine-tools, and all kinds of automatic production lines, pipelines and assembly lines which need speed-regulation, etc. Its main features are follows:

1. High speed-regulating precision: up to  $0.5i \ll 1$  rotation.
2. Large speed-changing range: The speed ratio ranges from 1/1.4 to 1/7 freely.
3. High in strength and long in service life.
4. Smooth in driving, low in noise, stable in performance, continuous in running and front-to-back in running direction.
5. Convenient to regulate the speed, and compact in structure and small in volume.
6. Full in sealing and suitable for any environment.
7. Easy in adaptation: it can be combined with all kinds of speed reducers, as to achieve low stepless speed-changing.
8. Made of high-quality aluminium alloy diecast in forming, good-looking in appearance, light in weight and it never gets rusty.

### Type & Expressions

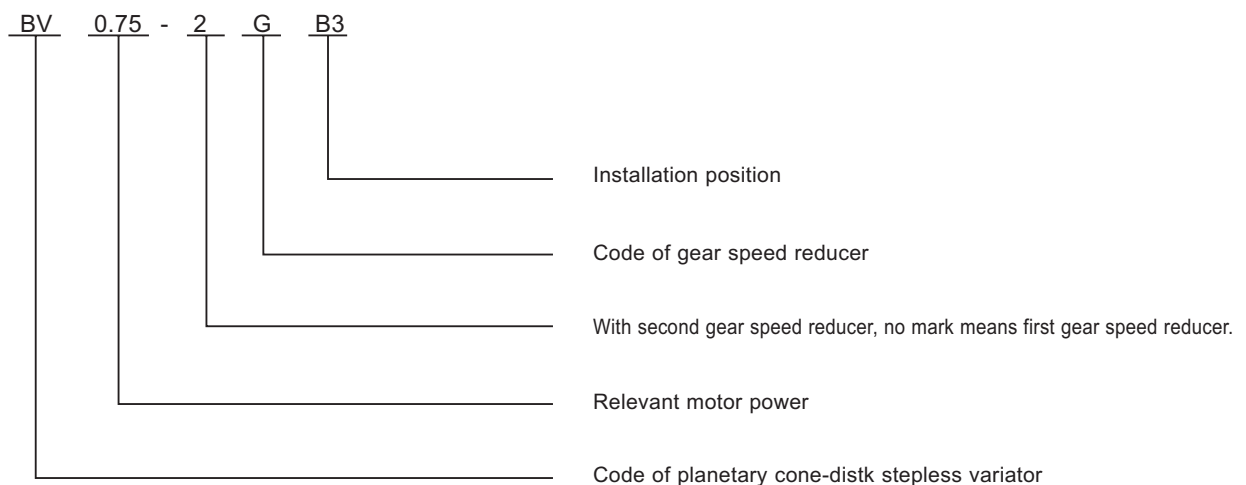

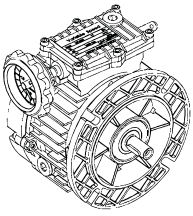

## BV SERIES BASIC MODEL INSTALLATION DIMENSIONS

### B3 Model

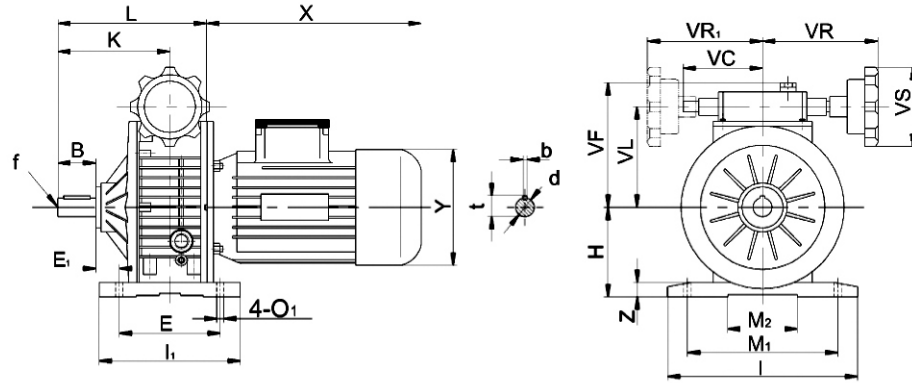

Type	B	d(j6)	E	E <sub>1</sub>	H	I	I <sub>1</sub>	K	L	M <sub>1</sub>	M <sub>2</sub>	O <sub>1</sub>	VC	VF	VL	VR	VR <sub>1</sub>	VS	b	f	t	X	Y	Z
BV 0.18B3	23	11	105	17.5	80	145	120	87.5	135.5	110	71	9	71	111	78	110	110	85	4	4	12.5	200	120	10
BV 0.37B3	30	14	104	20	93	149	125	104	140	120	96	9	71	123	90	110	110	85	5	M6	16	227	141	10
BV 0.75B3	40	19	125	26	113	190	150	125.5	179	160	135	11	79	140	107	120	120	110	6	M6	21.5	268	160	15
BV 1.1B3	40	24	105	34.5	100	207	130	136	187	160	115	13	-	124	102	150	-	110	8	M8	27	265	195	15
BV 1.5B3	50	24	115	53.5	123	241	150	165	238	190	143	13	-	144	122	150	-	110	8	M8	27	290	195	18
BV 2.2B3	60	30	230	25	150	300	270	191	268	245	190	14	-	188	150	160	-	110	8	M8	33	320	215	25
BV 3.0B3	60	30	230	25	150	300	270	191	268	245	190	14	-	188	150	160	-	110	8	M8	33	320	215	25
BV 4.0B3	60	30	230	25	150	300	270	191	268	245	190	14	-	188	150	160	-	110	8	M8	33	340	240	25
BV 5.5B3	70	35	250	33	200	365	290	201	319	315	245	18	-	192	194	194	-	110	10	M10	38	395	275	30
BV 7.5B3	70	35	250	33	200	365	290	201	319	315	245	18	-	192	194	194	-	110	10	M10	38	435	275	30

### B5 Model

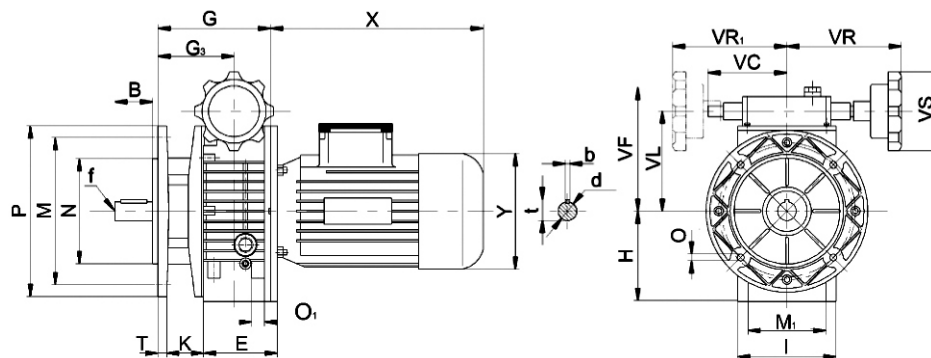

Type	B	d(j6)	E	G	G <sub>3</sub>	H	I	M	M <sub>1</sub>	N	D	D <sub>1</sub>	P	T	K	VC	VF	VL	VR	VR <sub>1</sub>	VS	b	f	t	X	Y
BV 0.18B5	23	11	50	112.5	64.5	70	72	115	60	95	9	M6	140	3.5	46	71	111	78	110	110	85	4	-	12.5	200	120
BV 0.37B5	30	14	40	110	74	80	90	130	77	110	9	M8	160	3.5	53	71	123	90	110	110	85	5	M6	16	227	141
BV 0.75B5	40	19	58	139	85.5	100	98	165	84	130	11	M8	200	3.5	60	79	140	107	120	120	110	6	M6	21.5	268	160
BV 1.1B5	40	24	-	147	95	98	207	165	-	130	11	-	200	3.5	-	-	124	102	150	-	110	8	M8	27	265	195
BV 1.5B5	50	24	-	188	115	126	241	165	-	130	11	-	200	3.5	-	-	144	122	150	-	110	8	M8	27	290	195
BV 2.2B5	60	30	-	208	131	150	270	265	-	230	15	-	300	4	-	-	188	150	160	-	110	8	M8	33	320	215
BV 3.0B5	60	30	-	208	131	150	270	265	-	230	15	-	300	4	-	-	188	150	160	-	110	8	M8	33	320	215
BV 4.0B5	60	30	-	208	131	150	270	265	-	230	15	-	300	4	-	-	188	150	160	-	110	8	M8	33	340	240
BV 5.5B5	70	35	-	244	131	200	-	300	-	250	19	-	350	5	-	-	192	194	194	-	110	10	M10	38	395	275
BV 7.5B5	70	35	-	244	131	200	-	300	-	250	19	-	350	5	-	-	192	194	194	-	110	10	M10	38	435	275

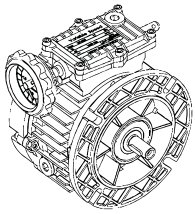

## BV SERIES BASIC MODEL-SINGLE STAGE GEAR BOX INSTALLATION DIMENSIONS

### B3 Model

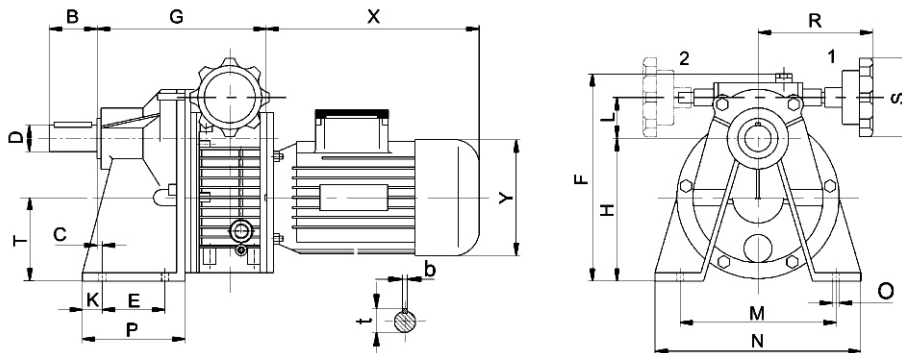

Type	B	C	D	t	b	E	F	G	H	Y	L	M	N	O	P	R	S	T	X	K
BV 0.18-GB3	40	18	19	21.5	6	45	162	189	108	120	33	115	130	9	80	110	85	66	200	16
BV 0.37-GB3	50	6	24	27	8	70	187	190	130	141	39	150	190	10	110	110	85	79	227	15
BV 0.75-GB3	60	7	28	31	8	70	228	225	160	160	46	165	210	12	130	130	110	99	268	25

### B5 Model

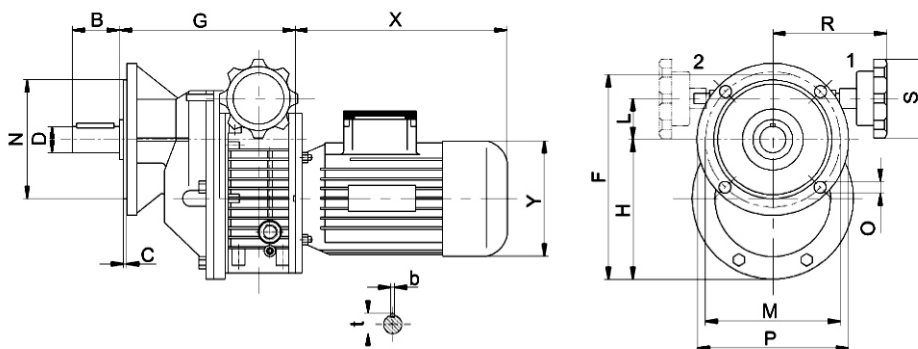

Type	B	C	D	t	b	F	G	H	Y	L	M	N	O	P	R	S	X
BV 0.18-GB5	40	3	19	21.5	6	176	191	105	120	33	115	95	9	140	110	85	200
BV 0.37-GB5	50	4	24	27	8	208	192	128	141	39	130	110	10.5	160	110	85	227
BV 0.75-GB5	60	4	28	31	8	255	227	155	160	46	165	130	12.5	200	130	110	268

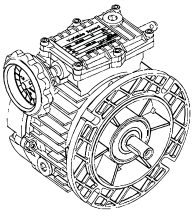

## BV SERIES BASIC MODEL-DOUBLE STAGE GEAR BOX INSTALLATION DIMENSIONS

### B3 Model

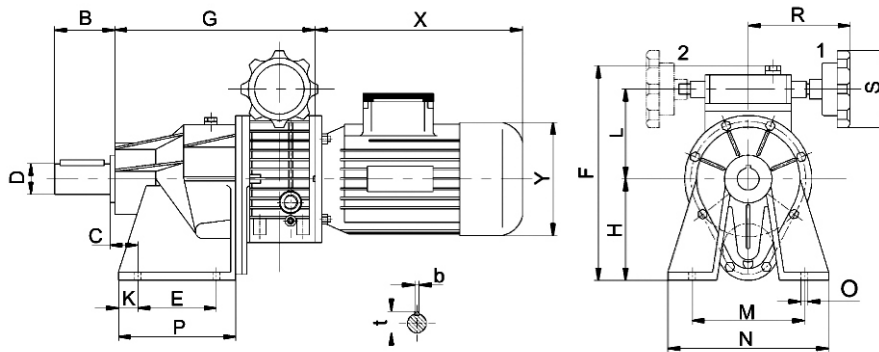

Type	B	C	D	t	b	E	F	G	H	Y	L	M	N	O	P	R	S	X	K
BV 0.18-2GB3	40	27	19	21.5	6	70	201	229	105	120	78	105	130	9	120	110	85	200	21
BV 0.37-2GB3	55	25	28	31	8	85	216	238	110	141	90	150	190	10	140	110	85	227	19
BV 0.75-2GB3	65	34	32	35	10	90	261	278	154	160	107	185	230	12	150	130	110	268	21

### B5 Model

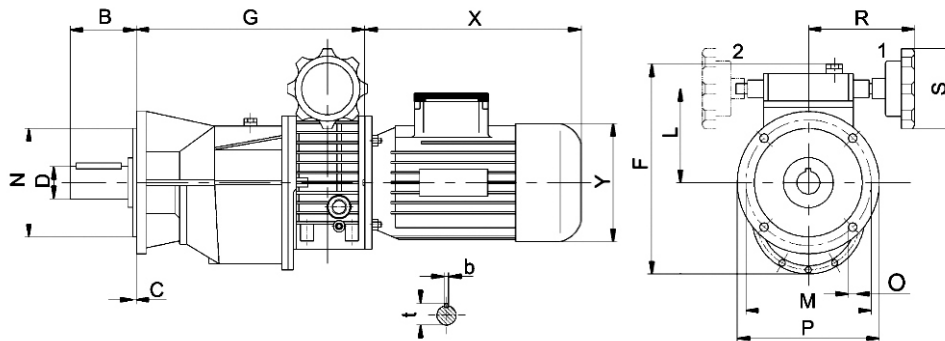

Type	B	C	D	t	b	F	G	Y	L	M	N	O	P	R	S	X
BV 0.18.2GB5	40	3	19	21.5	6	198	231	120	78	115	95	9	140	110	85	200
BV 0.37.2GB5	65	4	28	31	8	223	240	141	90	130	110	10.5	160	110	85	227
BV 0.75.2GB5	65	4	32	35	10	262	280	160	107	165	130	12.5	200	130	110	268

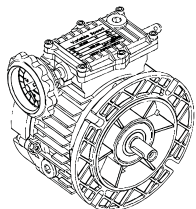

## PERFORMANCE PARAMETERS

### Basic Model

Input	Type	Ratio	Output	
			$n_2$ (r/min)	$M_2$ (N.m)
0.18KW	BV 0.18	1.6~8.2	880~170	1.5~3
0.37KW	BV 0.37	1.4~7	1000~200	3~6
0.55KW	BV 0.55	1.4~7	1000~200	4~8
0.75KW	BV 0.75	1.4~7	1000~200	6~12
1.1KW	BV 1.1	1.4~7	1000~200	9~18
1.5KW	BV 1.5	1.4~7	1000~200	12~24
2.2KW	BV 2.2	1.4~7	1000~200	18~36
3.0KW	BV 3.0	1.4~7	1000~200	24~48
4.0KW	BV 4.0	1.4~7	1000~200	32~64
5.5KW	BV 5.5	1.4~7	1000~200	45~90
7.5KW	BV 7.5	1.4~7	1000~200	59~118

### Basic model-gear speed reducer

Input	Type	Ratio	Output	
			$n_2$ (r/min)	$M_2$ (N.m)
0.18KW 4P $n_1=1400$ r/min	BV 0.18-G	2.5	352~68	3.5~7.4
		3.3	266~51.5	4.7~10
		5	176~34	7~15
	BV 0.18-2G	8	110~21	10~20
		11	80~15.5	14~28
		13.3	66~13	17~34
		16.6	53~10	21~42
0.37KW 4P $n_1=1400$ r/min	BV 0.37-G	20	44~8.5	25~50
		2.5	400~80	7.3~15
		3.3	300~60	9.5~20
	BV 0.37-2G	5	200~40	15~30
		8	125~25	20~40
		11	90~18	28~56
		13.3	75~15	34~68
0.75KW 4P $n_1=1400$ r/min	BV 0.75-G	16.6	60~12	42~84
		20	50~10	53~106
		2.5	400~80	15~29
	BV 0.75-2G	3.3	300~60	19~38
		5	200~40	30~60
		8	125~25	40~80
		11	90~18	54~108
BV 0.75-2G	13.3	75~15	68~136	
	16.6	60~12	84~168	
	20	50~10	96~140	

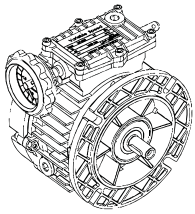

## USAGE SPECIFICATIONS

1. The shaft lines should be kept concentric when the coupling is connected with a motor. The installation error should not be more than the tolerance value of the coupling.
2. When the output shaft is installed with the coupling or belt wheel, they should be pressed into the screw hole on shaft end, or assembled by heating. No hammering should be done on it.
3. The mechanical stepless speed variator is not used in such a occasion where overload or running-blockage happen to occur.
4. Speed-regulation should be effected in running. No turning the hand wheel of speed-regulation when the machine stops.
5. The banking screws of speed-regulation on tow ends under the operating box are well adjusted. Please don't touch them.
6. This set is not suited to work in the environment of above 40°C, especially more than 45°C when the temperature goes up.

When the variator starts to work (without load), the temperature rise higher than normal, up to 40~50°C above the environment temperature. After 60-80 hours running, the temperature will decrease gradually. Finally, the temperature will be about 20°C higher than surrounding and keep stable. The high temperature at beginning do not damage any parts of variator and do not effect its service life. (Suggestion: running without load at first.)

7. The liquid lubricating oil is used for the speed variator. Its trade mark is Ub-3. Please check up the oil level before use.
8. The machine is filled with lubricating oil before leaving the factory. When it starts to work up to 1000 hours for the first time, its lubricating oil should be replaced.
9. The lubricating oil level inside the speed variator should be kept at the height of one-third in the oil scale. Users should usually check up the height of oil level.

It is strictly prohibited to operate it short of lubricating oil. The air screw nut on the operating box is screwed up for preventing from oil leakage in moving when leaving the factory.

It should be loosed when it start to run. It is strictly forbidden to use it before loosing.

Standard Position

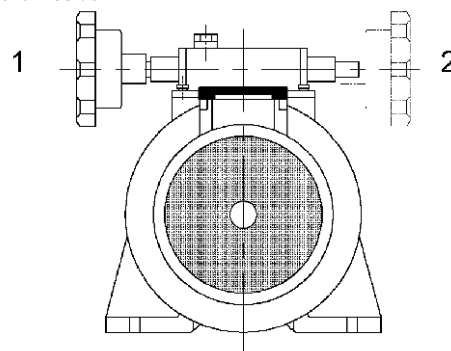

Hand wheel position diagram

# www.bonvario.com



# BONVARIO

---

## ITALY

RIDUTTORI  
MOTORIDUTTORI  
VARIATORI CONTINUI  
MOTORI ELETTRICI A.C.

GEARBOXES  
GEARED MOTORS  
SPEED VARIATORS  
A.C. ELECTRIC MOTORS

ITALY ■ GERMANY ■ USA ■ CANADA ■ INDIA



### ITALY

Via San Francesco d'Assisi N-22A  
Torino - 10121  
ITALY  
Email: [info@bonvario.com](mailto:info@bonvario.com)



### GERMANY

Gablonzer Ring 29 / 4186  
Kaufbeuren  
Bayern - 87600  
GERMANY  
Email : [sales.germany@bonvario.com](mailto:sales.germany@bonvario.com)



### USA

4281 Express Lane  
Suite N-4164  
Sarasota, FLORIDA 34238  
UNITED STATES OF AMERICA  
Email : [sales.usa@bonvario.com](mailto:sales.usa@bonvario.com)



### CANADA

795 Lakeshore Dr, Suite-307  
Dorval, Quebec  
H9S 0A8  
CANADA  
Email : [sales.canada@bonvario.com](mailto:sales.canada@bonvario.com)



### INDIA

15/24, Main Mathura Road  
Badarpur, Near NTPC gate  
New Delhi – 110044  
INDIA  
Email: [sales.india@bonvario.com](mailto:sales.india@bonvario.com)  
Tel.: 011-29949306, 29949307

CHANNEL PARTNER: